



Series R53 smart sensors measure bi-directional (application and removal) bottle cap torque and other applications in the food and beverage, cosmetics, consumer products, and other industries. Adjustable posts accommodate a range of sample sizes, while alternative gripping attachments (high capacities only) accommodate unique shapes. Capacities available from 10 ozFin to 100 lbFin [7 to 1,150 Ncm]. Compatible with Mark-10 indicators (sold separately) through unique Plug & Test™ technology.

## Specifications

<b>Accuracy:</b>	±0.5% of full scale + indicator
<b>Safe Overload:</b>	MR53-10Z - MR53-50Z: 300% of full scale MR53-12 - MR53-100: 150% of full scale
<b>Weight:</b>	MR53-10Z - MR53-50Z: 2.2 lb [1.0 kg] MR53-12 - MR53-100: 5.4 lb [2.5 kg]

## Optional Items

<b>CT001</b>	Flat jaws, pair, for MR53-12 - MR53-100
<b>CT003</b>	Adjustable jaws, pair, for MR53-12 - MR53-100



< Unique Plug & Test™ technology allows for interchangeable sensors to be used with a Mark-10 indicator. All calibration and configuration data is saved in the smart connector.



< The Plug & Test™ connector locks into the receptacle in the indicator when fully inserted. Dual buttons on the indicator housing release the connector for easy removal. Gold plated spring contacts ensure long lasting and reliable connection.



^ Low capacity Series R53 torque sensor is shown in a cosmetic packaging test.



^ Higher capacity Series R53 torque sensors accommodate larger sample sizes, as shown in the beverage closure application above.

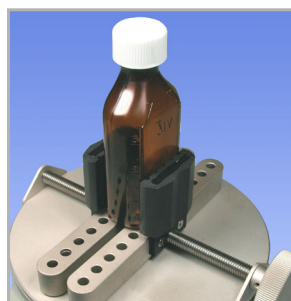

^ Optional CT001 flat rubber jaws are ideal for square or odd shaped samples.



^ Optional CT003 adjustable jaws include 4 rubber-edged gripping arms per jaw. Arms may be independently repositioned in 45° increments to accommodate unique samples.

## Dimensions in [mm]

### MR53-10Z - MR53-50Z

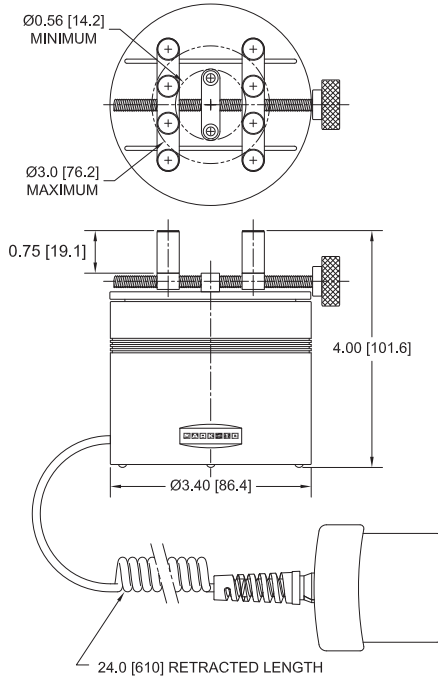

### MR53-12 - MR53-100

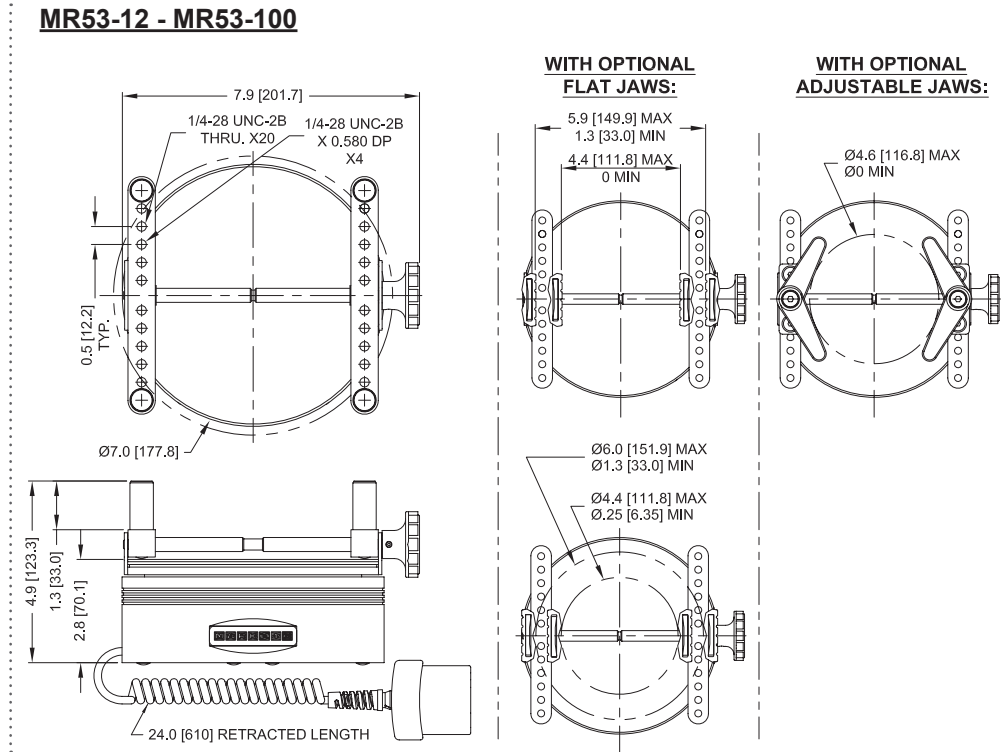

## Capacity x Resolution

Model No.	With Models 7i & 5i indicators								With Model 3i indicator			
	lbFin	ozFin	lbFft	gFcm	kgFmm	Nmm	Ncm	Nm	lbFin	ozFin	kgFmm	Ncm
MR53-10Z	-	10 x 0.01	-	700 x 0.5	7 x 0.005	70 x 0.05	7 x 0.005	-	-	10 x 0.01	7 x 0.005	7 x 0.005
MR53-20Z	-	20 x 0.02	-	1400 x 1	14 x 0.01	140 x 0.1	14 x 0.01	-	-	20 x 0.02	14 x 0.01	14 x 0.01
MR53-50Z	-	50 x 0.05	-	3600 x 5	36 x 0.05	350 x 0.5	35 x 0.05	-	-	50 x 0.05	36 x 0.05	35 x 0.05
MR53-12	12 x 0.01	192 x 0.1	1 x 0.001	-	-	-	135 x 0.1	1.35 x 0.001	12 x 0.01	192 x 0.2	-	135 x 0.1
MR53-50	50 x 0.05	800 x 0.5	4 x 0.005	-	-	-	570 x 0.5	5.7 x 0.005	50 x 0.05	800 x 1	-	570 x 0.5
MR53-100	100 x 0.1	1600 x 1	8 x 0.01	-	-	-	1150 x 1	11.5 x 0.01	100 x 0.1	1600 x 2	-	1150 x 1